

Sprague can help you solve your high pressure needs

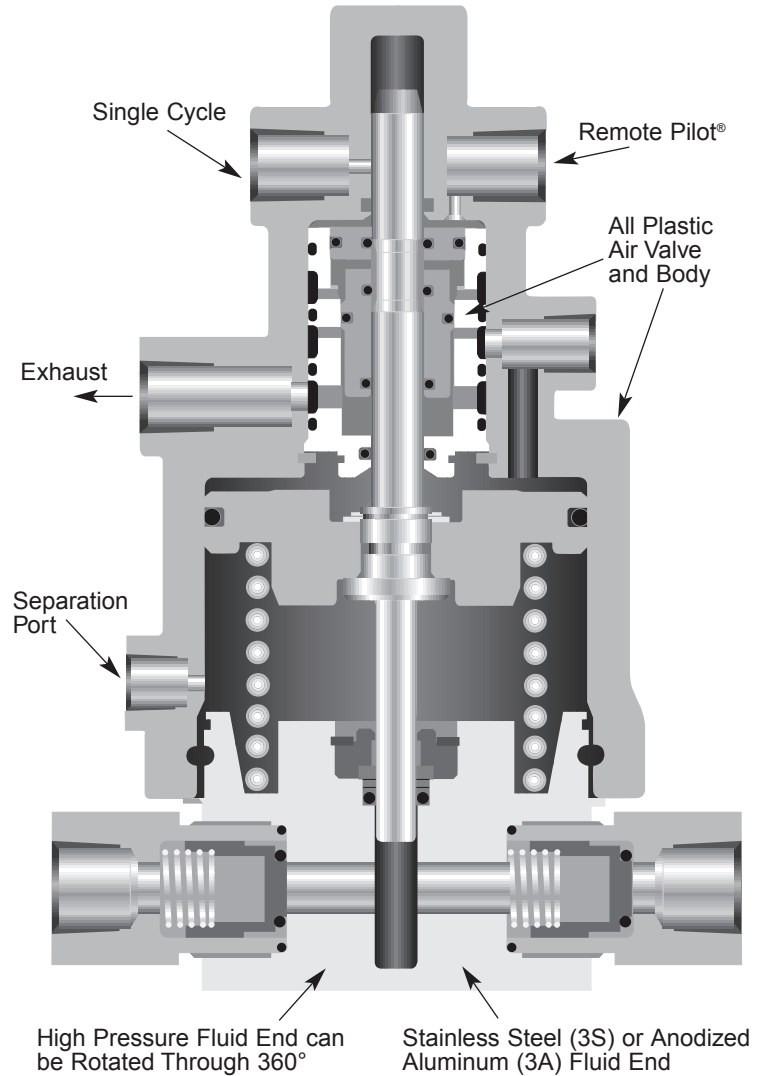

Sprague's SM-3 range of high pressure mini-pumps offer the following benefits to our customers

Easier and lower cost maintenance – use of plastics in air drive module, unique air valve and non bolted construction make for simple overhaul. The SM-3 has less components than competitive products. No lubrication required.

Water or oil options – pump can be supplied to suit oil applications or more demanding water based systems.

Better value for money – various air valve operating modes are supplied as standard and can be readily field configured.

Flexibility – manual operation option available so pump can be used as a back up to main pump or in low volume lab applications.

How to get the best performance from your Sprague SM-3 air operated pump

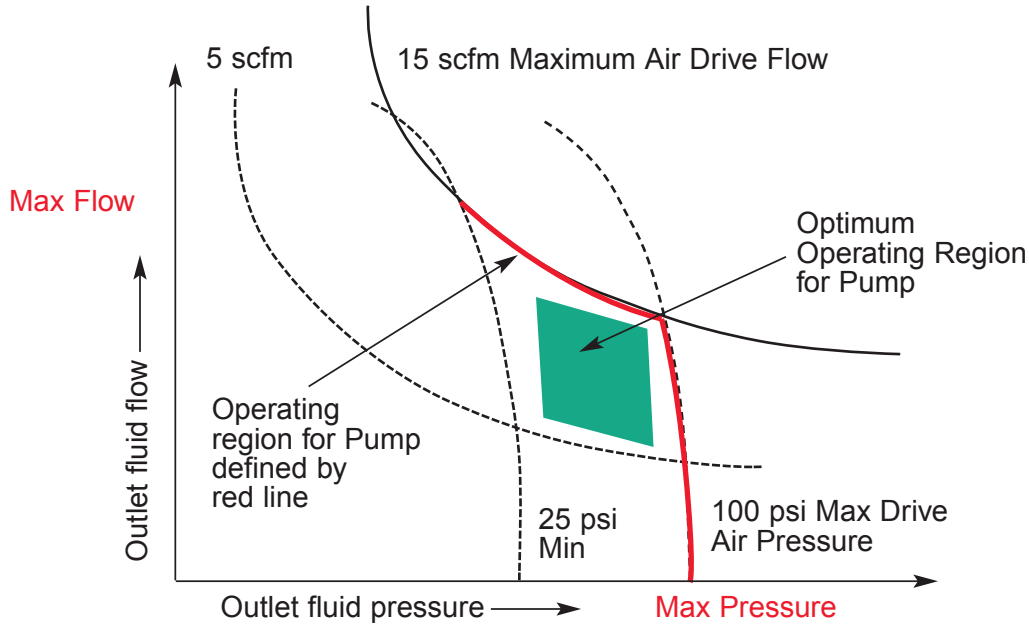

The pump performance is defined by a combination of outlet pressure and flow

AIR FLOW dictates how fast the pump can cycle and hence flow rate depends fundamentally on how much air is available. However as the pump pressure increases, the flow rate will decrease and the air consumption reduces to zero at stall pressure. Normal performance is based on maximum operating Air Supply of 15 SCFM @ 100 PSI.

AIR PRESSURE available produces a discharge pressure dependent on the RATIO of the pump.

Only need pressure - flow rate unimportant

Where a maximum pressure is required and the flow rate is unimportant then the available air pressure has to be sufficient for the selected ratio.

Air drive pressure x Actual Ratio = maximum discharge pressure.

Where a maximum flow at a specified pressure is required this “duty point” has to be within the constraints of available air flow and pressure.

Need pressure and flow

This needs to be plotted on the flow curves for the pump and should, if possible, be within the optimum operating region as shown above, which is within the operating region dictated by the min and max limits for air flow and air pressure.

PUMP RATIO SELECTION CHART

For the following pump models: SM-3A, SM-3S

Actual Ratio	Nominal Ratio	Nominal Output Pressure	Disp. Per Stroke Cu.In.	LIQUID DISCHARGE PRESSURE – PSI															
				0	100	200	350	500	1000	1500	2M	4M	6M	8M	10M	12M	15M	20M	
				CAPACITIES – CUBIC INCHES PER MINUTE APPROXIMATE															
5.75:1	5:1	500	1.050	550	330	275	180												
11.5:1	10:1	1000	0.527	476	350	200	180	150	10										
23:1	20:1	2000	0.263	305	280	210	160	110	75	60	15								
40.3:1	35:1	3500	0.150	158	140	120	100	90	60	50	40								
69:1	60:1	6000	0.085	98	90	80	70	60	31	25	22	17							
115:1	100:1	10000	0.053	58	55	53	50	48	40	30	21	16	14	10					
173:1	150:1	15000	0.035	39	38	37	36	35	28	25	20	12	11	9	7	6			
259:1	225:1	22500	0.023	24	23	22	21	20	18	17	16	9	8	7	6	5	4	3	

Nominal Performance (Based on Operating Air Supply of max 15 scfm @ 100 PSI)



Flow Performance

SM-3X-005 PUMP PERFORMANCE
(Based on Operating Air Supply of 12 - 15 SCFM)

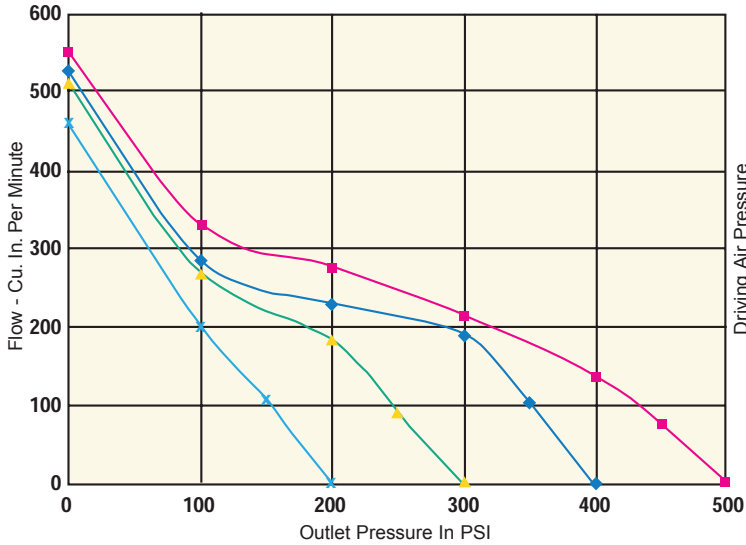

SM-3X-010 PUMP PERFORMANCE
(Based on Operating Air Supply of 12 - 15 SCFM)

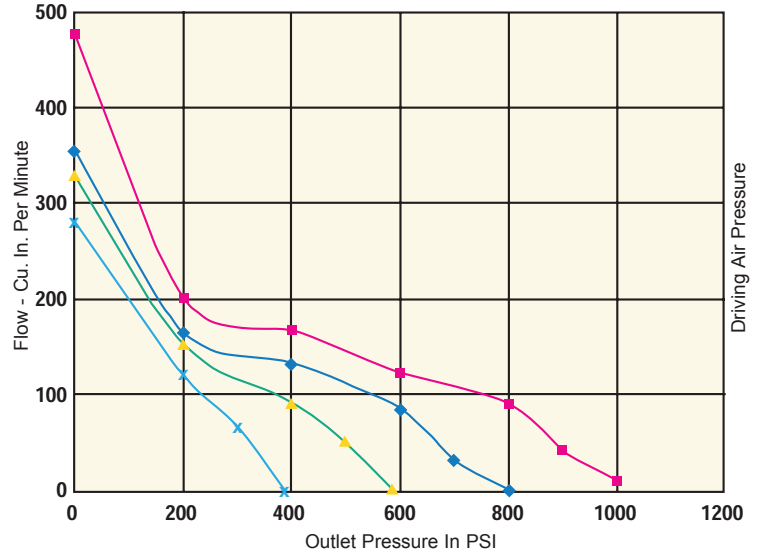

SM-3X-020 PUMP PERFORMANCE
(Based on Operating Air Supply of 12 - 15 SCFM)

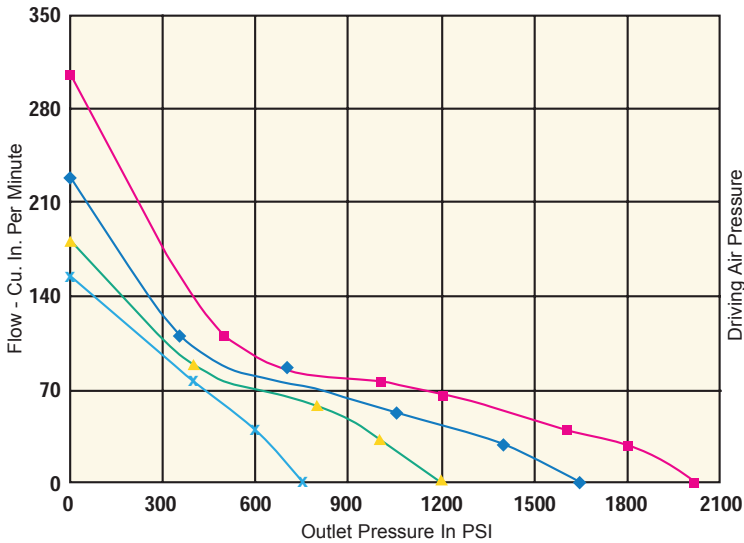

SM-3X-035 PUMP PERFORMANCE
(Based on Operating Air Supply of 12 - 15 SCFM)

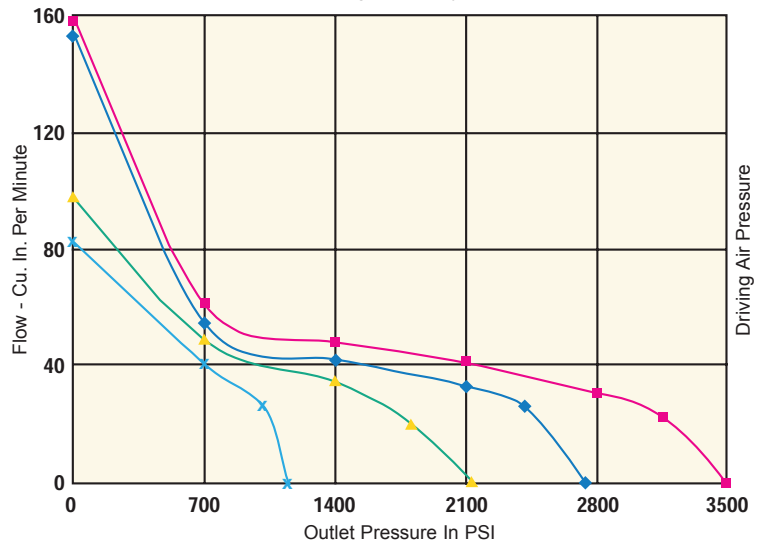

Driving Air Pressures

- 100 psi
- ◆ 80 psi
- ▲ 60 psi
- ✕ 40 psi

SM-3X-060 PUMP PERFORMANCE

(Based on Operating Air Supply of 12 - 15 SCFM)

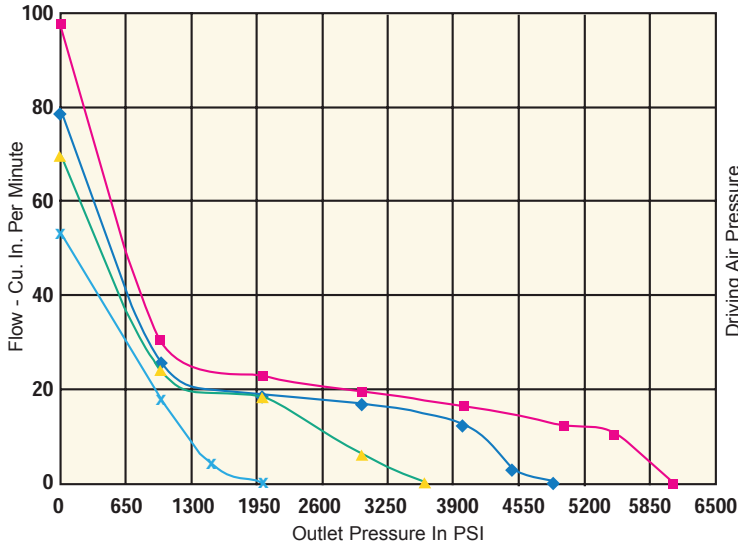

SM-3X-100 PUMP PERFORMANCE

(Based on Operating Air Supply of 12 - 15 SCFM)

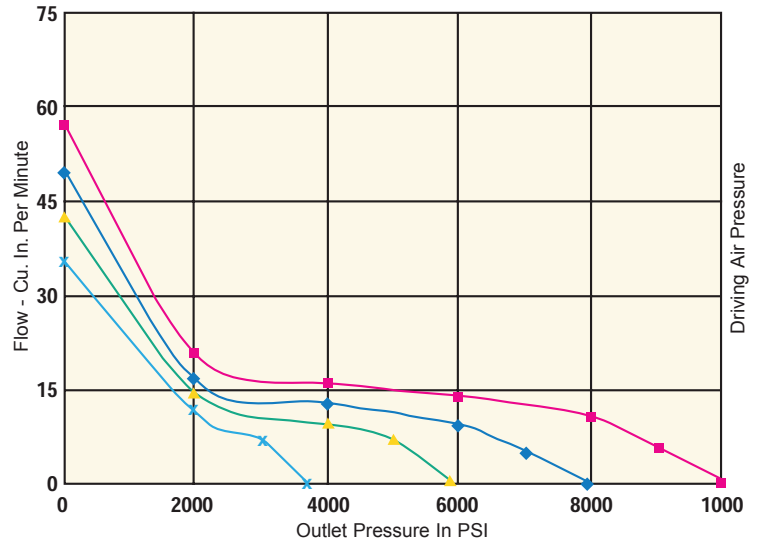

SM-3X-150 PUMP PERFORMANCE

(Based on Operating Air Supply of 12 - 15 SCFM)

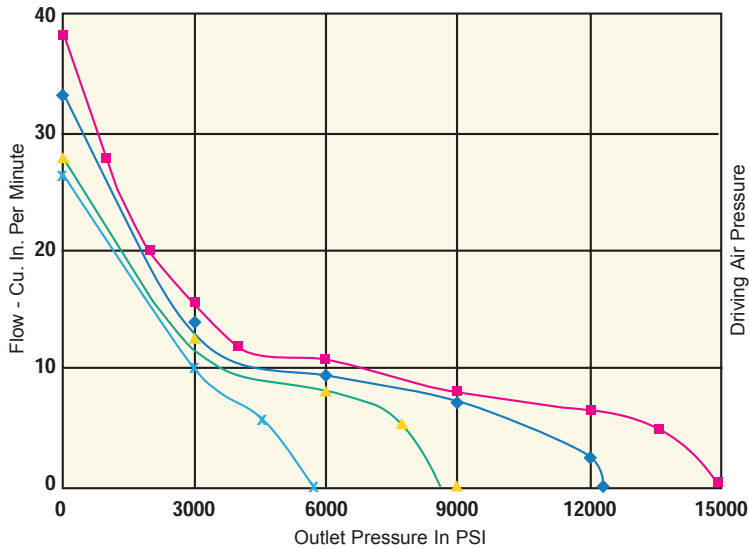

SM-3X-225 PUMP PERFORMANCE

(Based on Operating Air Supply of 12 - 15 SCFM)

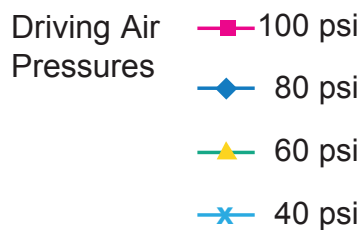
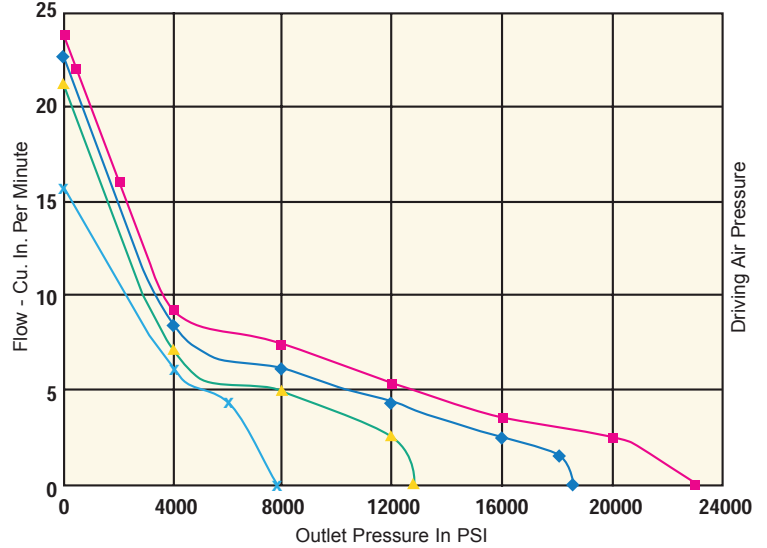

Sprague SM-3 air operated pumps - Options

MATERIALS

SM-3 pumps are supplied with stainless steel (**SM-3S**) or Aluminium (**SM-3A**) fluid ends and all plastic air modules.

Anodized aluminium bodies are for oil and non-corrosive applications. SS bodies are for aqueous and most other fluids.

RATIO

See pump ratio selection chart.

AIR AND FLUID PORTS

SM-3 pumps are supplied with **NPT** as standard for air and fluid connections. However, pumps capable of pressures in excess of 10,000 psi have coned and threaded outlet fluid connections **NBS 9/16"-18 thread, 1/4 HP** in place of NPT as per the attached table.

SEALS

UHMWPE with Nitrile is supplied as standard. Selection of the best seal package is based on fluid temperature and chemical compatibility. Contact your local distributor or Sprague for required assistance.

EXHAUST

SM-3 pumps are supplied with a muffler/silencer as standard. When using non breathable gas to drive the pump, air pilot exhaust and main drive exhaust must be piped away to a safe area.

SEPARATION

An 1/8" threaded port is provided in the air cylinder body as standard. This section of the pump separates the air drive from the fluid section.

AIR CONTROL OPTIONS

The SM-3 pumps are supplied with internal pilot as standard. Various control options can be configured at installation. The air valve is the heart of the pump and this feature provides the maximum flexibility in controlling how the pump operates and how the exhaust air is directed.

Remote Pilot (R) allows the customer to start and stop the pump by using a remote air pilot switch. In this mode the air pilot switch senses the pressure output from the pump and can be arranged to switch the pump on or off at preset high or low pressures. The customer supplies the remote air pilot switch. This feature is extremely useful for systems engineers where a specific pressure must be maintained.

Single Cycle Mode (S) is used where the pump is required to accurately discharge a given flow. The S configuration provides a control feature that when a pulse of air is supplied to the port the pump will travel one full cycle. The pulse rate can be set using standard air logic controls to govern the flow rate accurately. This feature is particularly useful in chemical injection applications.

MANUAL OPERATION (H)

The SM-3 can be supplied with a hand lever for manual operation. This option allows the pump to be used as a back up to a main pump or in low volume lab applications.

ORDERING

CATALOG NUMBER	PUMP RATIO
SM - 3A Aluminum	- 005 - 010 - 020
SM- 3S Stainless	- 035 - 060 - 100 - 150* - 225*
	*(stainless steel only)

To order a standard stainless steel pump, specify ratio eg: SM-3S-10. To order a standard anodized aluminum pump, specify ratio eg: SM-3A-10.

To order options, simply add the option number(s) eg:

SM-3A-10-H
SM-3S-10-R
SM-3S-35-02-H
SM-3A-150-H

OPTIONS

PORTS	SEALS	CONTROLS
NPT – ratio's -005 -010 -020 -035 -060 (STANDARD)	UHMWPE/ NITRILE (STANDARD)	Internal Pilot Supply (STANDARD)
NBS – ratio's -100 - 150 - 225 (STANDARD)	- 02 PTFE/ NEOPRENE - 03 PTFE/VITON - 04 PTFE/EPR	- R Remote Pilot Supply (user configured) - S Single Cycle (user configured) - H Manual Hand Lever

Sprague SM-3 Dimensional Data

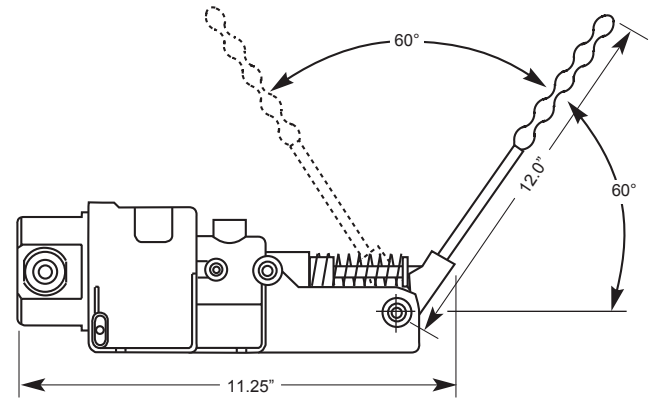
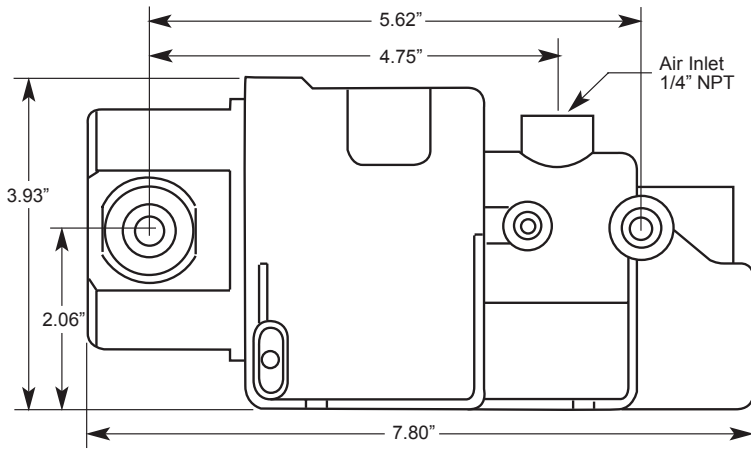

Hand Pump Option

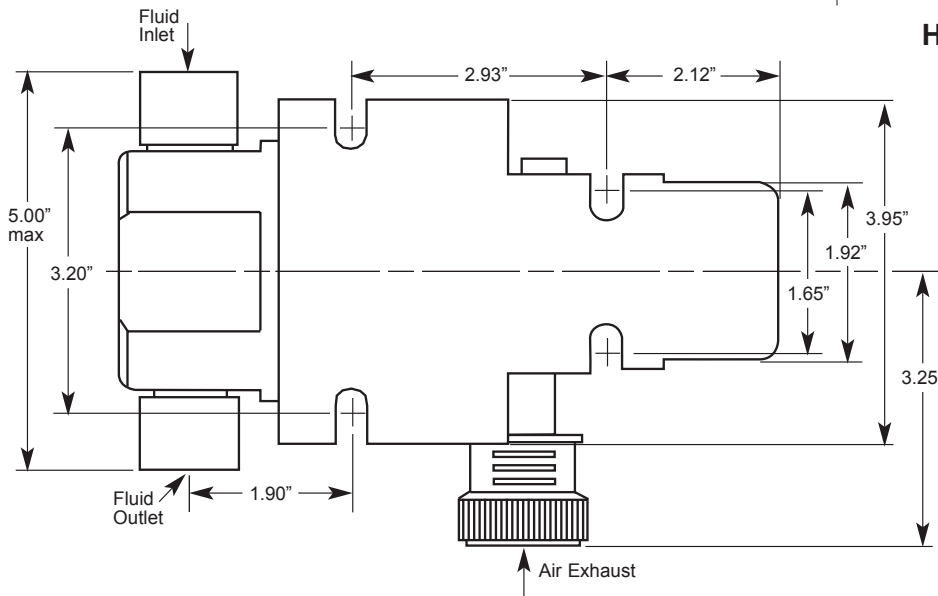

Bolt Hole Machining use
1/4" (6mm) Fasteners

- STD. ALUM. BODY 4.5 LBS.
- STD. ST. STL. BODY 6.75 LBS.
- HAND ALUM. BODY 5.75 LBS.
- HAND ST. STL. BODY 8.00 LBS

Porting – Standard pumps

Model	Fluid Inlet Port	Fluid Outlet Port B	Air Inlet Remote and Single Port
SM-3#-050	3/8" NPT	3/8" NPT	1/4" NPT
SM-3#-010	3/8" NPT	3/8" NPT	1/4" NPT
SM-3#-020	3/8" NPT	3/8" NPT	1/4" NPT
SM-3#-035	3/8" NPT	3/8" NPT	1/4" NPT
SM-3#-060	3/8" NPT	3/8" NPT	1/4" NPT
SM-3#-100	1/4" NPT	9/16"-18 NBS (1/4" HP)	1/4" NPT
SM-3#-150	1/4" NPT	9/16"-18 NBS (1/4" HP)	1/4" NPT
SM-3#-225	1/4" NPT	9/16"-18 NBS (1/4" HP)	1/4" NPT

Mounting bolts – 1/4" or M6