

# ADVANCED AIR DRIVEN PUMP SYSTEM

# DIMENSIONS, WEIGHTS & PORTING

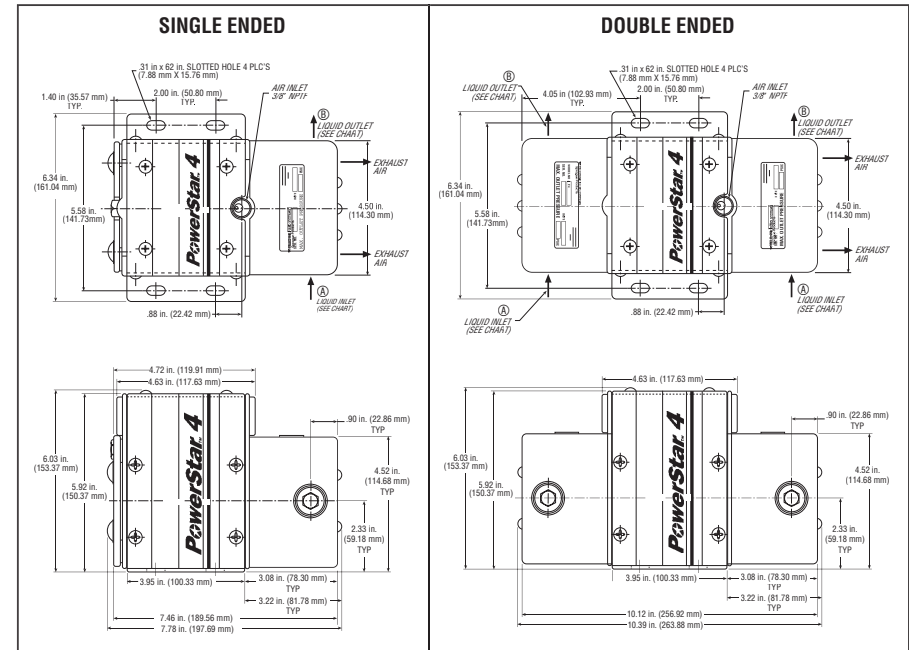
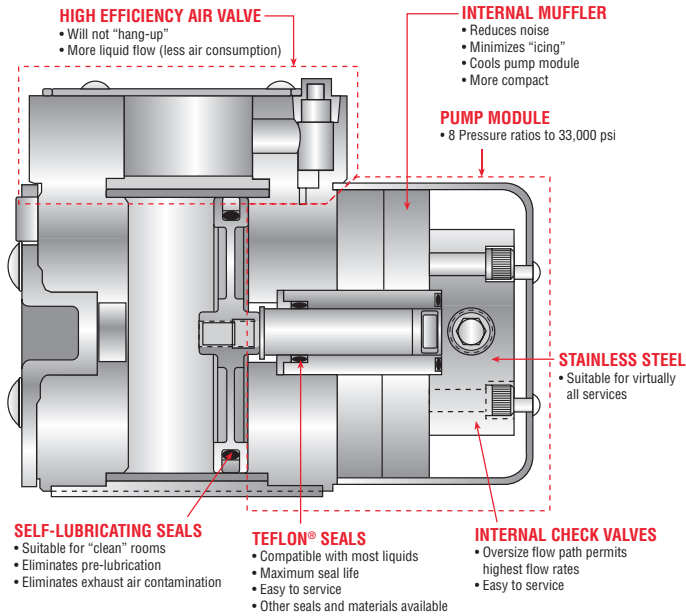

NOTE: Double ended units, fully plumbed, available upon request.

## HOW THE PUMP WORKS

The PowerStar™ 4 pumps develop high output pressures by applying the principle of differential areas. The pump has a large area air piston (air driven at low 5 to 100 psi pressures). This air piston drives a small area liquid piston that pumps liquids to high pressures.

The liquid output pressure is determined by the ratio between the area of the air drive piston, the area of the liquid drive piston and the applied driving air pressure. The relationship of the area of the air piston to the liquid piston is referred to as the pump ratio which is indicated in the number following the air module number (P4).

*Example.* The P45 pump has a nominal ratio of 5 to 1 or 5 psi liquid pressure for each 1 psi of operating air pressure.

In operation, the P45 pump using 100 psi of input air pressure could produce a maximum liquid output of 480 psi; 80 psi air - 370 psi output; 60 psi air - 270 psi output; and 40 psi air - 180 psi output. Output pressures will vary and be reduced by 5 to 10% through internal friction depending on the lubricity of the liquid.

By regulating the incoming air supply at the pressure regulator, the liquid output can be infinitely adjusted through the pump's pressure range.

Pump Model	Inlet Port Liquid	Outlet Port Liquid	Inlet Port Air	Approx. Shipping Weight
P45	3/4" NPTF	1/2" NPTF	3/8" NPTF	16 lbs (7.26 Kg)
P410	3/4" NPTF	1/2" NPTF	3/8" NPTF	16 lbs (7.26 Kg)
P421	1/2" NPTF	3/8" NPTF	3/8" NPTF	16 lbs (7.26 Kg)
P434	1/2" NPTF	3/8" NPTF	3/8" NPTF	16 lbs (7.26 Kg)
P464	1/2" NPTF	3/8" NPTF	3/8" NPTF	16 lbs (7.26 Kg)
P4114	3/8" NPTF	9/16-18 NBS	3/8" NPTF	16 lbs (7.26 Kg)
P4203	3/8" NPTF	9/16-18 NBS	3/8" NPTF	16 lbs (7.26 Kg)
P4333	3/8" NPTF	9/16-18 NBS	3/8" NPTF	16 lbs (7.26 Kg)
DOUBLE ENDED	Same	Same	Same	21 lbs (9.53 Kg)

## PART IDENTIFICATION

**PowerStar™ 4**

**COMPLETE UNIT EXAMPLES** (using a 64:1 ratio):  
 Standard 64:1 ratio pump ..... P464  
 Separated 64:1 ratio pump..... P4S64  
 Double ended 64:1 ratio pump..... S64P4S64  
 Double ended 64:1 ratio pump  
 w/ air controls.....S64P4S64C  
 Double ended 64:1 ratio pump w/ air  
 and high pressure controls .....S64P4S64CP

	Air Module P4	Liquid Module 4F64	Sep Kit 4SK64	Air Controls 4ACKIT	Pressure Controls P
Air Motor Module P4	1				
Liquid Pump Module 4F64		1			
Single Air & Liquid Module P464	1	1			
Single Separated P4S64	1	1	1		
Double Ended S64P4S64	1	2	2		
Double Ended w/ Air S64PS64C	1	2	2	1	
Double Ended w/ Air & Pressure Controls S64P4S64CP	1	2	2	1	1

## HOW TO ORDER

To order a hydraulic pump, the ratio of the pump must be selected.

Define the liquid pressure and flow requirements for the application as well as the available air pressure and volume; then refer to the Pump Performance Charts on pages 4 & 5.

From the chart, select a pump that exceeds the requirements. Drive air may be throttled if flow must be reduced.

Use this pump liquid module ratio number and add it to the end of the pump air motor module number. *Example:* P45.

Nominal liquid module displacements are as follows:

5:1	⇒	2.4 cu in
10:1	⇒	1.2 cu in
21:1	⇒	.6 cu in
34:1	⇒	.37 cu in
64:1	⇒	.2 cu in
114:1	⇒	.11 cu in
203:1	⇒	.06 cu in
333:1	⇒	.04 cu in

## PUMP NUMBERING SYSTEM

**Typical Models**      **Model Number**  
 Standard 64:1 Ratio Pump..... P464  
 w/ separator kit.....P4S64  
 w/ air controls.....P464C  
 w/ pressure & air controls .....P464CP  
 Double ended  
 64:1 Ratio Pump\* .....S64P4S64

\* Double ended pumps require separation on both sides

Nitrile is the standard elastomer. The pumps can be furnished with other o-rings: Viton, EPR, Neoprene.

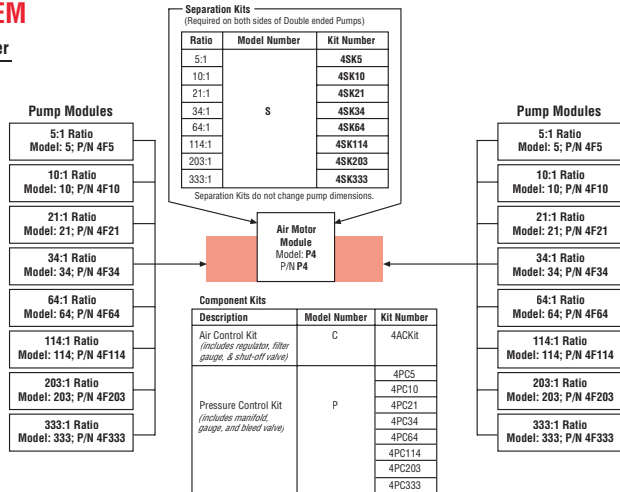

## The modular PowerStar 4 System features

- A patented design
- One common air motor module for all eight ratios
- Easy conversion to separated (non-contaminating) configuration
- A double-ended unit that provides even higher flows
- Safe operation in hazardous environments
- Automatic shut-off at set pressure
- Stainless steel wetted parts
- Easy assembly and service for air motor and high pressure modules (field assembly requires careful alignment; see Assembly & Operating Instructions)

## The PowerStar 4 System is ideal for

- Hydrastatic testing of pressure vessels using various liquids (avoid running the pump dry or sudden release of outlet pressure)
- Low volume, high pressure testing
- Low volume, liquid transfer (higher pressure capability than double diaphragm pumps)

P4-( )

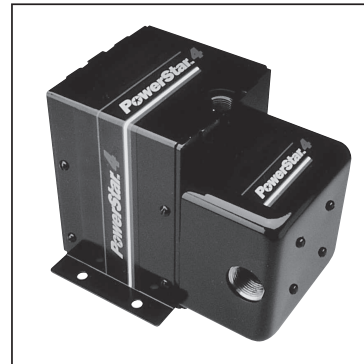

SINGLE ENDED

( )-P4-( )

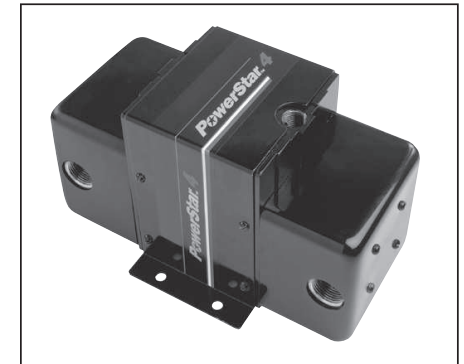

DOUBLE ENDED

## The PowerStar 4 System is suitable for most water applications

- Cleanliness and lubricity of liquid being pumped will affect pump seal life.
- A five-micron inlet filter is recommended.
- For applications that contain highly contaminated air and/or liquids, contact the Factory.

SAMPLE PERFORMANCE CHART

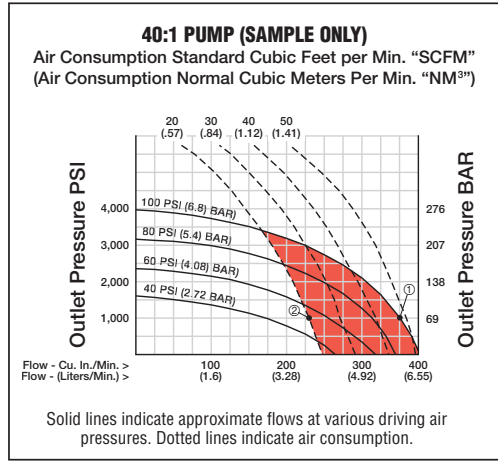

EXAMPLES:

- ① With **100 PSI** (6.8 BAR) driving air, the pump will consume **50 SCFM** (1.41 NM<sup>3</sup>/MIN) at an operating pressure of **1,000 PSI** (68 BAR) and will produce an outlet flow of **358 Cu. In./Min.** (5.9 LPM).
- ② If the volume of compressed air is reduced to **20 SCFM** (.57 NM<sup>3</sup>/MIN), the flow will be reduced to **225 Cu. In./Min.** (15.3 Liters). Shaded area indicated flow reduction.

NOTES:

Most air compressors will produce **4 to 5 SCFM** of compressed air per horsepower at **100 PSI**.

All air driven pumps will operate on low air volumes as long as the supply of air is sufficient to operate the air selector valve.

Performance charts are based upon air supply stated, pumping oil (Mil-H-5606) with flooded suction.

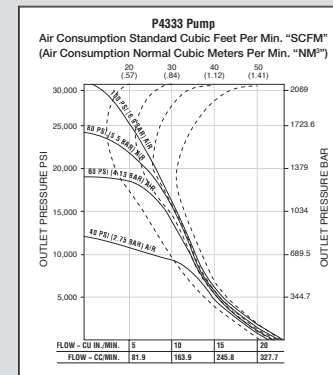
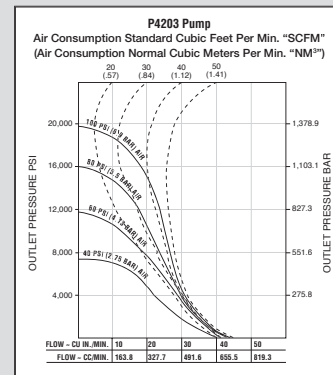
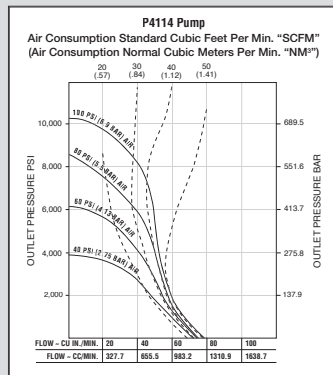
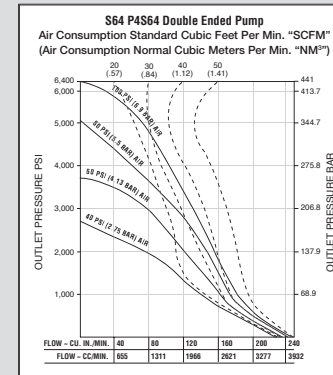
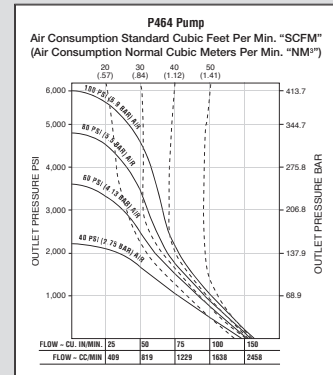
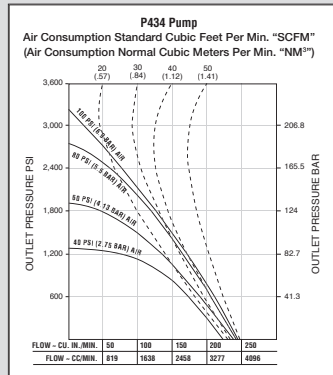
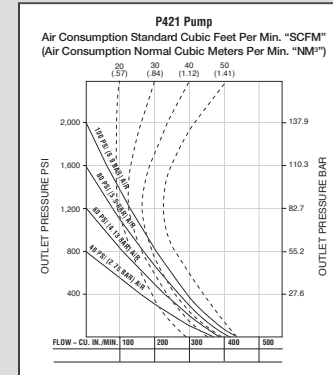
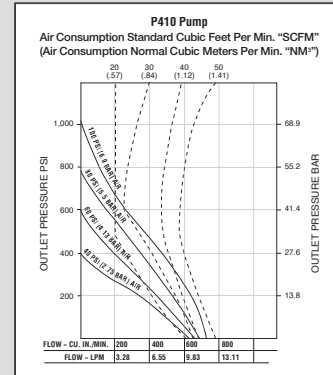
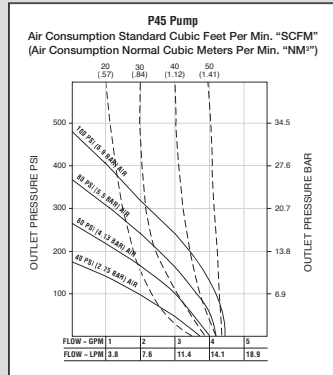

"TYPICAL" OR "NOMINAL" PERFORMANCE, DOUBLE ENDED PUMPS = 1.6 X SINGLE PUMP FLOW